

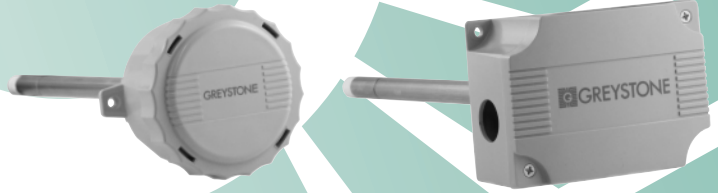

GREYSTONE ENERGY SYSTEMS INC

DUCT HUMIDITY TRANSMITTER RH200 Series

The RH200 series uses a highly accurate and reliable Thermoset Polymer based capacitance humidity sensor and state-of-the-art digital linearization and temperature compensated circuitry to monitor humidity levels. The sensor is encapsulated in a 228.60 mm (9") long by 12.7 mm (0.5") diameter 304 S/S probe. An 60 micron HDPE filter protects the sensor for contaminants. A variety of enclosures are available. Additional options such as integrated temperature sensor and LCD display are available.



SPECIFICATION:

Sensor Type:.....Thermoset Polymer based Capacitive
 Range:.....0 to 100% RH
 Accuracy:.....±2, 3, or 5% RH (5 to 95% RH)
 Response:.....15 Seconds typical
 Temp Dependence:.....±0.05% RH/ °C
 Hysteresis:.....±1.5% RH maximum
 Repeatability:.....±0.5% RH typical
 Linearity:.....±0.5% RH typical
 Operating Range:.....-40 to 85°C (-40 to 185°F)
 Power Supply:.....18 to 30 Vdc, 15 to 26 Vac
 Consumption:.....22 mA maximum
 Protection Circuitry:..Reverse voltage protected and output limited
 Output Signal:.....4-20 mA current loop, 0-5 or 0-10 Vdc (jumper-selectable)
 Output Drive @ 24 Vdc:..550 ohms max for current output
 10K ohms min for voltage output
 Internal Adjustments:..Clearly marked ZERO and SPAN pots
 Optional Temp.:.....RTD's or Thermistors - See ordering chart
 RH200 Probe:.....230 mm (9") probe length x 12.7 mm (1/2") diameter stainless steel with porous filter
 Enclosure:.....Standard (A) - ABS - UL94-5VB - IP61 (NEMA 2)
 Round (E) - ABS - UL94-5VB - IP65 (NEMA4X)
 Metal (M) - Gal. Steel - IP50 (NEMA1)
 Weatherproof (W) - Cast Alum. IP64 (NEMA3X)
 *In order to maintain the published NEMA/IP ratings, properly rated conduit or cable gland adapters must be used.
 Termination:.....Screw terminal block (14 20 22 AWG)
 Optional LCD:.....3 digit for 00.0 to 99.9% RH, 24 x 11 mm (0.95" w x 0.45" h) (A Enclosure only)

TYPICAL INSTALLATION:

For complete installation and wiring details, please refer to the product installation instructions.

The duct type probes are installed through a hole in the side of the duct to monitor a single point humidity within the duct. Install the probe in a straight section of duct at a suitable distance downstream from any heating, cooling or humidification devices.

Each enclosure style provides mounting tabs on the outside of the enclosure for ease of installation .

A terminal is provided for connection to the Building Automation System.

PART NUMBER SELECTED

PRODUCT SELECTION INFORMATION:

MODEL	Product Description
RH200	Duct Humidity Transmitter

CODE	Enclosure
A	ABS Enclosure, Standard
E	Round ABS w/ gasketed cover
M	Metal utility box
W	Weatherproof Aluminum

CODE	Accuracy
02	2%
03	3%
05	5%

CODE	Optional Temperature Sensor
L	100 Ω Plat. IEC 751, 385 Alpha, thin film
C	1000 Ω Platinum, IEC 751, 385 Alpha, thin film
F	1801 Ω, NTC Thermistor, ±0.2 C
E	3000 Ω, NTC Thermistor, ±0.2 C
D	10,000 Ω, Type 3, NTC Thermistor, ±0.2 C
J	10,000 Ω, Type 2, NTC Thermistor, ±0.2 C
K	20,000 Ω, NTC Thermistor, ±0.2 C
M	1000 Ω Nickel, Class B, DIN 43760
B	10K Ω, Type 3, NTC Therm, ±0.2 C c/w 11K shunt resistor
G	2,252K Ω, NTC Thermistor, ±0.2 C

CODE	Options
AC	LCD Display

Greystone Energy Systems, Inc. reserves the right to make design modifications without prior notice.

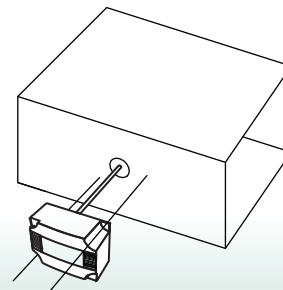

DIMENSIONS

ABS Enclosure (A)

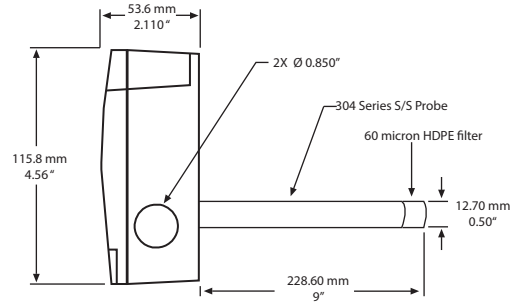
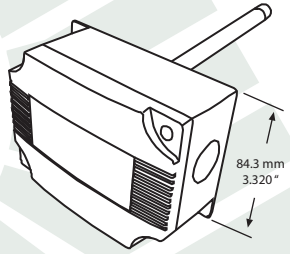

Round ABS Enclosure (E)

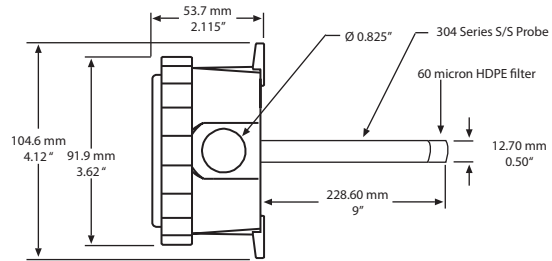
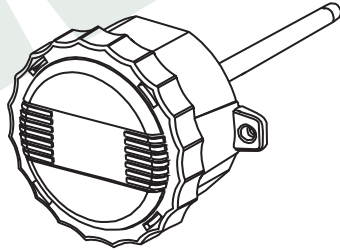

Metal Enclosure (M)

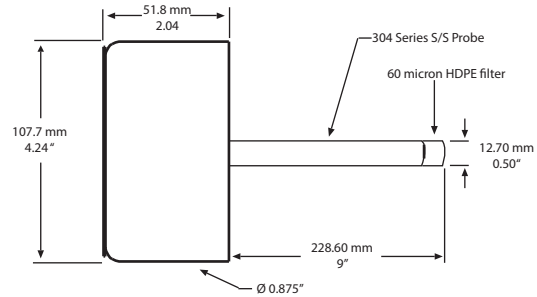
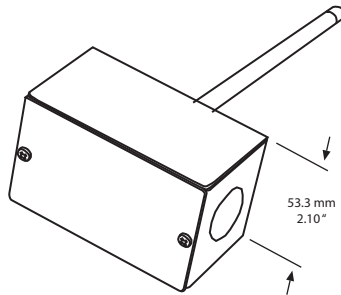

Weatherproof Enclosure (W)

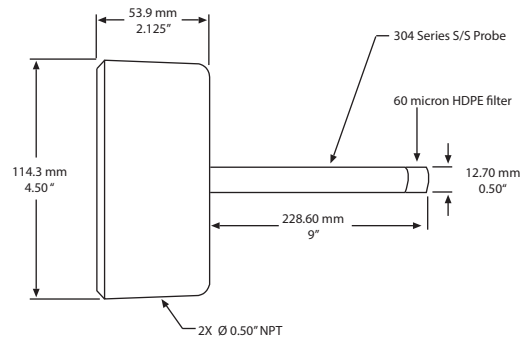
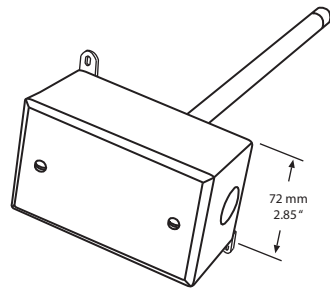

Greystone Energy Systems, Inc. reserves the right to make design modifications without prior notice.



GREYSTONE

ENERGY SYSTEMS INC

Greystone Energy Systems Inc.
150 English Drive, Moncton,
New Brunswick, Canada E1E 4G7

(506) 853-3057 Fax: (506) 853-6014
North America: 1-800-561-5611
e-mail: mail@greystoneenergy.com
www.greystoneenergy.com

RoHS
COMPLIANT



Greystone Energy Systems Inc. is one of North America's largest ISO registered manufacturers of HVAC/R sensors and transmitters for Building Automation Management Systems.

We have conscientiously established a worldwide reputation as an industry leader by maintaining leading-edge design technology, prompt technical support, and a commitment to on-time deliveries. We take pride in our Quality Management System which is ISO 9001 certified, assuring our customers of consistent product reliability.

GREYSTONE HAS AN ISO 9001 REGISTERED QUALITY SYSTEM